

HYVA OIL TANK KIT



KIT DR 165 WITH OPTIONS

Hyva

kit :

oil tank RM - 195L / 165L - MP

page # 1 / 1

kit number :

DR 165 M

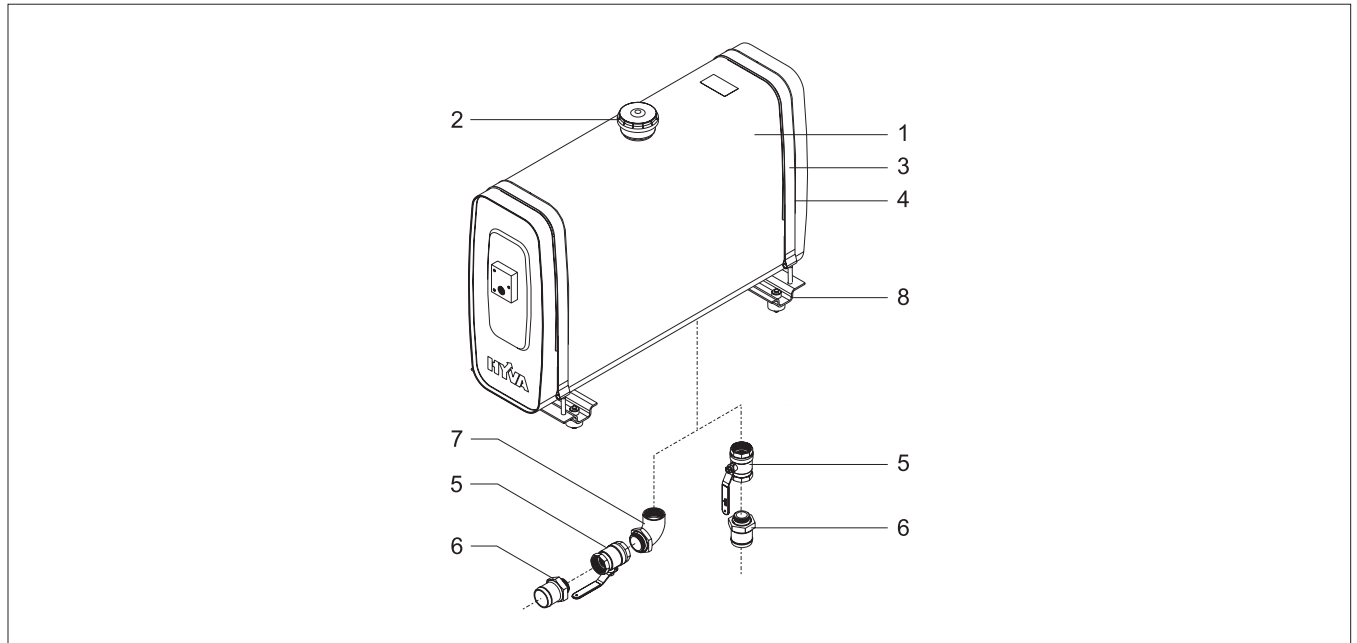

oil tank RM - 195L / 165L - MP:			DR 165 M
pos. code		description	qty.
1	140 15 060	oil tank RM - 195L / 165L - MP	1
2	081 02 116	filter air breather / filler cap	1
3	140 20 010	strap oil tank 307 x 674	2
4	140 20 020	strap rubber oil tank 307 x 674	2

oil tank RM - 195L / 165L - MP:			DR 165 MC
pos. code		description	qty.
1	140 15 060	oil tank RM - 195L / 165L - MP	1
2	081 02 116	filter air breather / filler cap	1
3	140 20 010	strap oil tank 307 x 674	2
4	140 20 020	strap rubber oil tank 307 x 674	2
5	147 80 980	ball valve 1½"BSPIT	1
6	147 99 015	hose pillar 0° 1¾" hose - 1½" BSPOT	1
8	142 21 530	tank support rear mounted	2
	142 21 582	tank support rubber	2
	081 01 078	vibration damper RM tank support	4

oil tank RM - 195L / 165L - MP:			DR 165 MD
pos. code		description	qty.
1	140 15 060	oil tank RM - 195L / 165L - MP	1
2	081 02 116	filter air breather / filler cap	1
3	140 20 010	strap oil tank 307 x 674	2
4	140 20 020	strap rubber oil tank 307 x 674	2
5	147 80 980	ball valve 1½"BSPIT	1
6	147 99 015	hose pillar 0° 1¾" hose - 1½" BSPOT	1
7	147 99 035	adapter 90° 1½" BSPIT - 1½" BSPOT	1
8	142 21 530	tank support rear mounted	2
	142 21 582	tank support rubber	2
	081 01 078	vibration damper RM tank support	4

kit options	
explanation of oil tank kit options	
C	- including ball valve & adapter 0° - 1¾" suction hose - tank support rear mounted + accessories
D	- including ball valve & adapter 90° - 1¾" suction hose - tank support rear mounted + accessories