

HYVA PISTON PUMPS



BENT AXIS TYPE

Hyva	piston pump type :	piston pump 080L - L - 4H
page # 2 / 2	part number :	145 64 635
	rotation :	anti clock wise seen from front side of pump

drawing for part number reference only

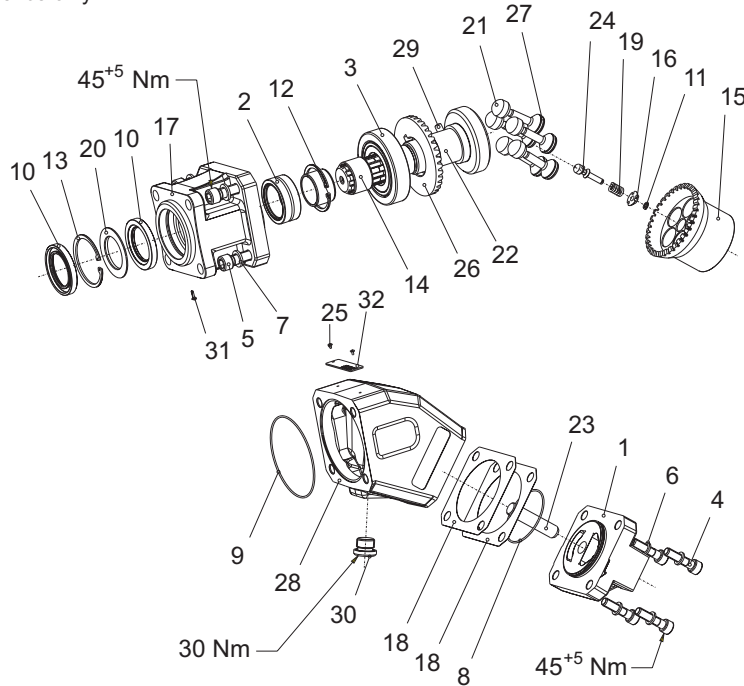

spare part list piston pump 145 64 635

pos.	code no.	description	qty.
1		rear cover	1
2		bearing	1
3		conic roller bearing	1
4		screw	4
5		screw	4
6		washer	4
7		washer	4
8		OR seal	1
9		OR seal	1
10		Viton seal	2
11		circlip	1
12		circlip	1
13		circlip	1
14		ring	2
15		cylinder block	1
16		centering lock	1
17		flange	1
18		seal side cover	2
19		cetering spring	1
20		keep plate	1
21		piston	5
22		shaft	1
23		pin	1
24		dowel pin	1
25		rivet	2

spare part list piston pump 145 64 635

pos.	code no.	description	qty.
26		gear	1
27		segment	5
28		pump body	1
29		dowel pin	1
30		steel plug	1
31		protection plug	1
32		name plate	1
	024 70 800	seal kit (comprises 8, 9, 10, 13 & 20)	1

general information and mounting possibilities.

The mentioned data on page 1 is for mineral based oil.
For other fluids, please contact our engineering dept.

The filtration as mentioned is for tippers only. For different applications we advise filtration according ISO 4406 class 17/14.

To avoid cavitation, the suction hose must be kept as short and straight as possible, and the minimum oil level in the oil tank must be above the inlet of the pump.

The direction of rotation of this pump can be changed by a skilled (hydraulic) engineer.
For information please contact our engineering dept.