

HYVA PT-TIPPING VALVE



PROPORTIONAL TIPPING VALVE - AIR OPERATING

Hyva

tipping valve type:

PT 1220-valve single pressure

page # 1 / 2

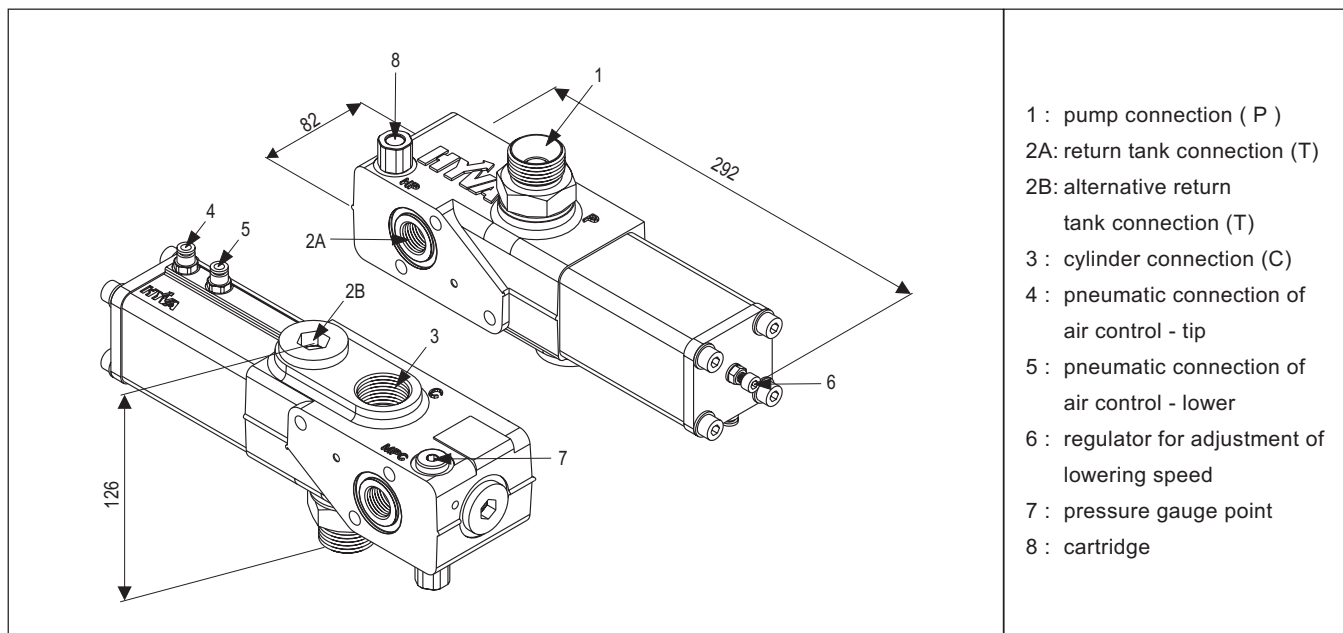

- 1 : pump connection (P)
- 2A: return tank connection (T)
- 2B: alternative return tank connection (T)
- 3 : cylinder connection (C)
- 4 : pneumatic connection of air control - tip
- 5 : pneumatic connection of air control - lower
- 6 : regulator for adjustment of lowering speed
- 7 : pressure gauge point
- 8 : cartridge

types

Part no.	description	max. pressure
147 67 315	PT - 1220 - 150	150
147 67 317	PT - 1220 - 170	170
147 67 319	PT - 1220 - 190	190
147 67 322	PT - 1220 - 220	220
147 67 325	PT - 1220 - 250	250
147 67 328	PT - 1220 - 280	280
147 67 335	PT - 1220 - 350	350

(Tank mounting kit 147 35 168 is included in box PT-valve)

specifications

type	: Spool valve with pressureless bypass in neutral. Oil flow in lowering position is proportional with pneumatic pilot pressure.
hydraulic connections	: G1"
max. peak pressure	: 350 bar
pneumatic pilot pressure	: 6-10 bar
max. flow	: 220 L/min. (see p-Q characteristic)
max. pressure on T-conn.	: 15 bar
filtration	: $\leq 25 \mu$ (ISO 18/13)
oil types	: mineral oil (DIN 51524 / 51525)
viscosity range	: 12 / 100 mm ² /s
temperature range	: -25 / + 80 °C
mass	: 6.4 kg

general information

general information

- Mount the valve according to the Hyva mounting instructions.
- Use the correct washers and adapters in the ports to prevent housing deformation.
Do not use adapters with tapered threads.
- To further prevent deformation of the valve housing, the mounting plate surface or block must be completely flat and plane.
- Do not weld to the valve.

p - Q characteristic

viscosity 30 mm²/s 50°C

This characteristic shows the pressure drop in relation to the flow.

- pump to tank (P→T)
- pump to cylinder (P→C)
- cylinder to tank (C→T)

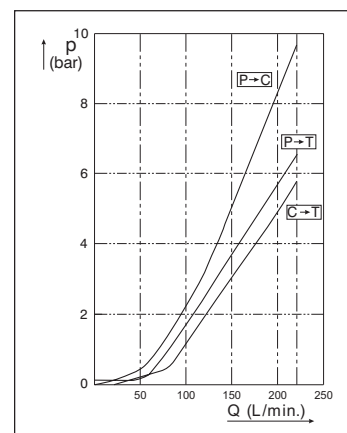

mounting

1 standard mounting on oil tank with direct oil return

The tipping valve must be mounted onto the tank that is equipped with a valve mounting block.

- Before mounting the valve, remove the plug underneath the valve and use the O-ring between valve-return line opening and valve block.
- Grease the O-ring light before mounting so it will stay in place.
- The return-line opening on the side of the valve should be blanked off with the plug and bonded seal from the kit. (Hyva mounting kit: 147 35 168)
- Fit the valve to the tank mounting block with the allen bolts and washers from the mounting kit.

2 remote mounting on the chassis

- Use the required Hyva mounting kit. (mount. kit: 147 35 208)
- Weld the chassis plate to the chassis.
- Fit the valve to the chassis plate with the allen bolts and washers from the mounting kit.

HYVA PT-TIPPING VALVE



PROPORTIONAL TIPPING VALVE - AIR OPERATING

Hyva tipping valve type: PT 1220-valve single pressure
page # 2 / 2

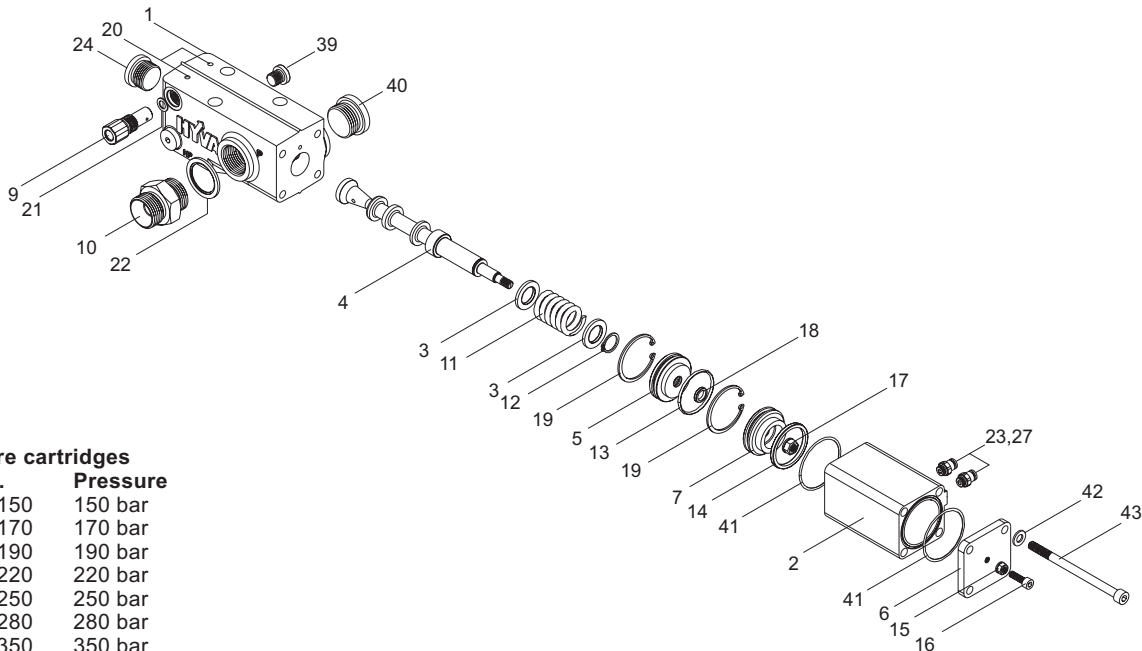

Pressure cartridges

Part no.	Pressure
147 71 150	150 bar
147 71 170	170 bar
147 71 190	190 bar
147 71 220	220 bar
147 71 250	250 bar
147 71 280	280 bar
147 71 350	350 bar

spare parts

No.	Part no.	Description	Qty.
1		housing machined	1
2	148 45 002	aluminium head	1
3		spring disk	2
4		plunger	1
5	148 45 005	closing plug	1
6		cover air	1
7	148 45 007	piston air cylinder	1
9	147 71 . . .	pressure cartridge	1
10	147 39 975 A	non return valve	1
11	148 45 011	spring	1
12		retaining ring	1
13	148 45 013	O-ring	1
14		quadring	1
15	148 45 011	sealing nut	1
16		alan bolt	1
17		sealing nut	1
18	148 45 018	quadring	1
19	148 45 019	retaining ring	2
20		expander	4

No.	Part no.	Description	Qty.
21		usit ring	2
22	013 13 848	bonded seal	1
23	148 10 517	straight coupling	1
24	148 45 024	blind plug	1
25		plastic stop (not shown)	1
26		plastic stop (not shown)	1
27		protection cap (not shown)	2
39	148 45 039	blind plug	1
40	148 45 040	blind plug	1
41		O-ring	2
42		washer	4
43		bolt	4

hydraulic symbol of the PT valve

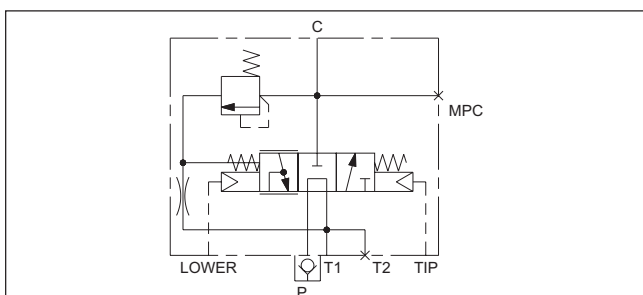

repair of the tipping valve

The valve should be dismantled in a clean area and using the correct tools.

If a fault has been developed which can be traced to the valve it is possible to replace the internal seals and O-rings.

All parts should be thoroughly cleaned before re-assembly.

Closing plug (pos. 5) must be removed/fitted with special tools ask Hyva for TBI-08-02-06 with the specified instructions.

- O-ring set: (pos. 13,14,18 & 41) = 148 44 010
- Air cylinder set (pos. 2, 5, 13 18 & 19) = 148 45 003

for specification see page # 1